



Elevate your CNC production.

Flexible Pallet Tower FPT

Plug-and-play automation for 300-630 mm pallets.



- **FAST DELIVERY**
with standardized solution
- **4 AND 5 AXIS MACHINES**
with and without APC
- **EASY TO OPERATE**
single view user interface
- **VERY COMPACT**
starting from 10 m² floorspace requirement

Automating machining processes and enabling unattended operation are proven ways to improve productivity and profits. Make the most out of 8,760 hours a year with the affordable and compact Flexible Pallet Tower (FPT) that offers configurable storage for up to 24 pallets with a small footprint.

Comparable payback example

	No automation	with FPT-500
Investment cost*	\$ 400,000	\$ 640,000
Machining hours/year **	1,600 h	5,100 h
Machine tool utilization rate	40 %	85 % ***
Total income per year (machining sales price \$ 100 / h)	\$ 160,000	\$ 510,000
Payback time	2y 6m	1y 3m

200 %
faster
payback

* calculated with a 5-axis HMC with modifications plus 18 pallets

** 50 weeks, 5 days per week, 2 manned shifts (+1 unmanned when automated) per day

*** no spindle time loss due manual setup changes + unmanned night shift

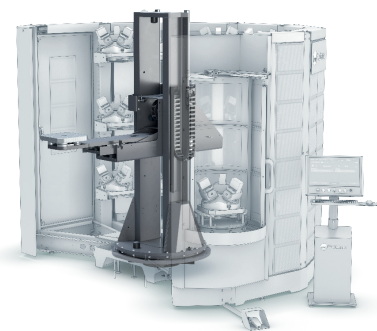
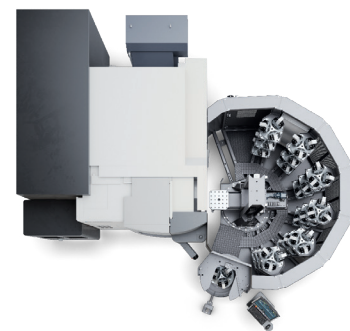

Comparison on 3 typical pallet automation systems

	No automation	Traditional OEM pallet tower	Flexible pallet tower
Machine tool brands	–	Limited	Any
Machine type	–	Machines with APC	Machines with/without APC
New or existing machine tools	–	New	Both
Unmanned production capacity (pallets)	1	Up to 21	Up to 24
Machine tool utilization	40 %	75 %	85 %
Variable load heights	–	No	Yes
Configurable pallet storage	–	No	From 2 to 4 levels
Single-view user interface	–	Yes	Yes
Order prioritization	Manual	Queue	Automatic
Real-time automatic KPI reports	No	No	Yes
Needed floor space	–	10 to 20 m ²	10 to 19 m²

At a glance

■ FPT-500 ■ FPT-1000

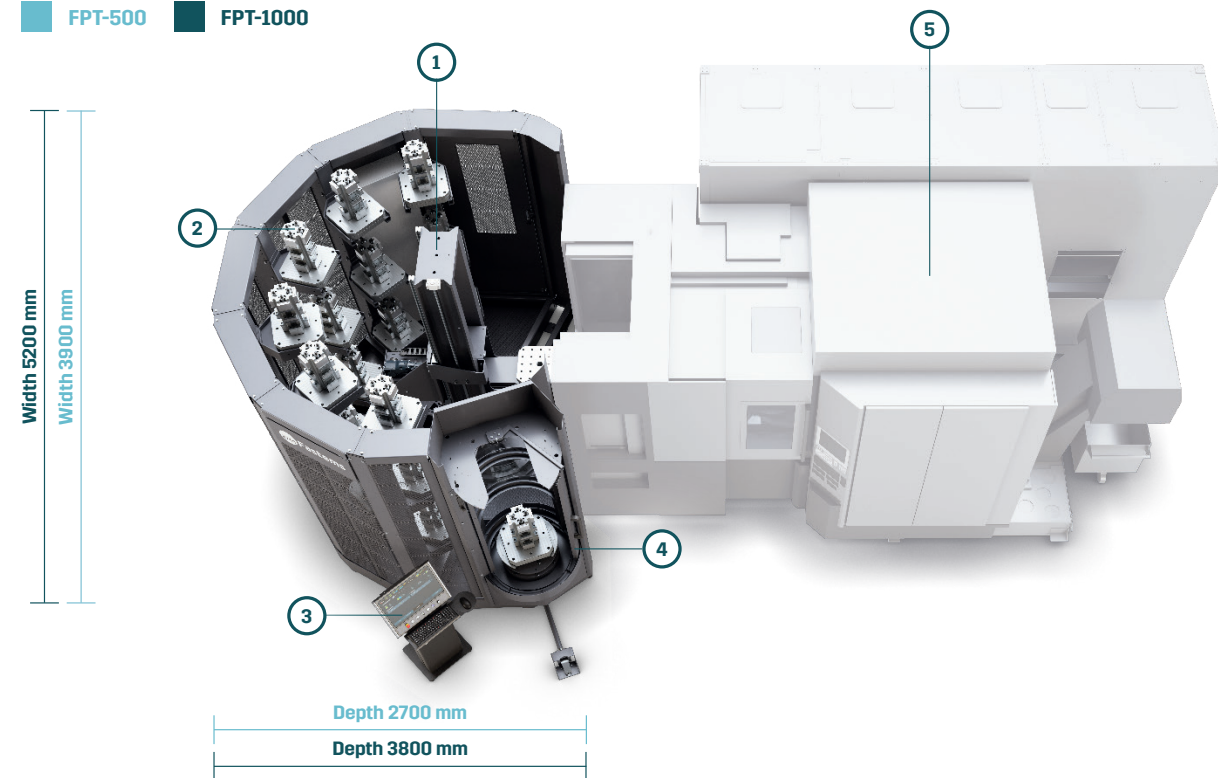

FPT is an affordable and compact automation system for 4 and 5 axis machine tools with or without automatic pallet changers (APC). With a wide library of ready-made machine interfaces, FPT integrates with any machine tool brand, plug-and-play.

FPT works with 300 to 630 mm pallets with two versions, requiring only 10 to 19 square meter

floor space. The system can be installed against a wall as well. The configurable storage offers capacity for 12 to 24 pallets in 2 to 4 levels, depending on load height.

The operator working area consists of a compact and ergonomic station for loading and unloading the work pieces; and a fully adjustable control panel to offer a comfortable operator experience.

- ① **Stacker crane**
- Pallet transportation
- ② **Pallet storage**
- Configurable from 2 to 4 levels
- Ask for two load heights optimization!
- ③ **Cell Controller**
- Touch operating panel
- Ergonomic with adjustable height
- ④ **Loading station**
- Ergonomic operation
- Clamping and unloading the parts
- At a glance system status
- ⑤ **Machine tool**
- With or without automatic pallet changer
- 300 to 630 mm pallets
- Over 90 brands already interfaced with Fastems



	FPT-500			FPT-1000		
Nominal machine pallet size	300-500 mm			500-630 mm		
Maximum load rotational diameter (D)	Ø 630 mm			Ø 900 mm		
Maximum load height (H) ¹	1200 mm	750 mm	500 mm	1200 mm	900 mm	600 mm
Storage levels	2	3	4	2	3	4
Storage places ²	12	18	24	12	18	24
Load weight ³	500 kg			1000 kg		
Width	3900 mm			5200 mm		
Depth	2700 mm			3800 mm		
Height (incl. load)	3100-3800 mm			3100-3800 mm		
Control system	Fastems MMS			Fastems MMS		

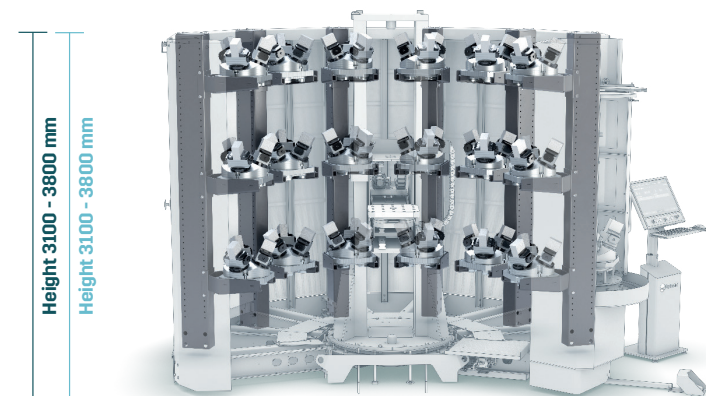

4 The pallet storage of FPT can be configured based on the load heights from two to four levels.

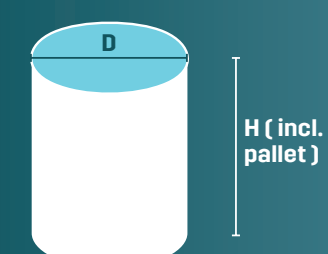

FEATURES

- 2-4 pallet shelves depending on load height
- Compact solution from 10 to 19 sqm
- 1 machine per system
- Integrated coolant handling
- MMS cell controller with touch panel
- Can be installed next to a wall

1, 3 Including pallet
2 Configuration depends on the selected machine tool

Manufacturing Management Software MMS

- Drag-and-drop production order
- Ready-made interfaces for hundreds of machine tools
- Recognizes resource bottlenecks in advance
- Automatic KPI reporting

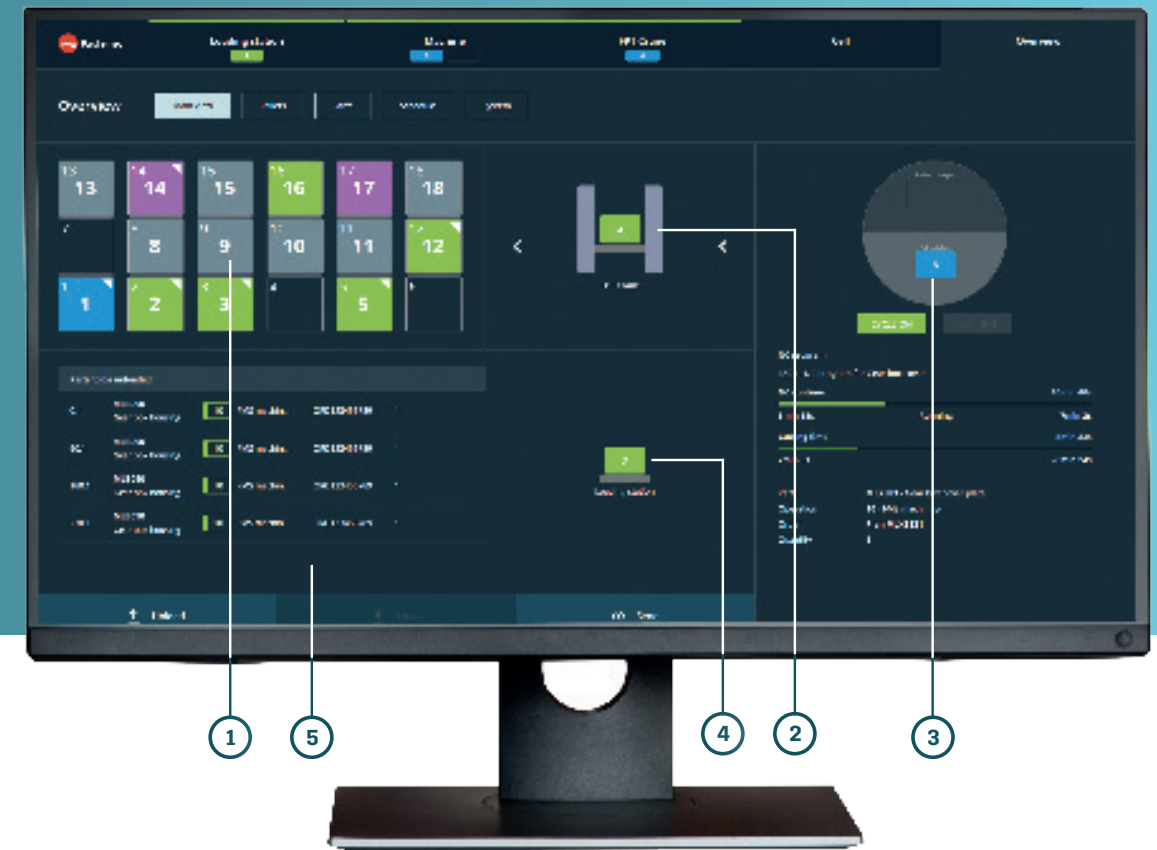

Easy production control

FPT is controlled by Fastems Manufacturing Management Software (MMS). With hundreds of ready-made machine tool interfaces you can enjoy the MMS benefits right from the day one.

MMS offers a single-view user interface with drag-and-drop production ordering and allows bringing new workpieces into the system in under 60 seconds. MMS also automatically tracks and reports the key performance indicators in real time.

Choose from 3 MMS plans

STANDARD

Easy to operate - enabling continuous, unattended production for you.

- Pallets are machined based on order-based work queue or FIFO.
- Intuitive user interface with guidance helps operator to focus on the most important tasks.
- Optional ERP interface.

ADVANCED

Offers transparent and predictive ways to keep you in control.

- Fine scheduling includes production order and resource simulation for up to 96 hours in advance.
- The MMS checks that all the needed NC programs and tools are available via machine tool integration.
- Order completion dates are calculated up to 6 months ahead.

ULTIMATE

Utilize your existing manufacturing data.

- Define your key performance indicators and view them at a glance with customizable Dashboard.
- Real-time machine status monitoring for continuous production optimization.
- Real-time remote monitoring with alarm functionality for unmanned production.

At a glance

- 1 Pallet storage overview**
- Drag and drop the pallet for machining
- 2 Stacker crane status**
- 3 Machine tool view**
- With or without APC
- Current NC program and machined part details
- 4 Loading station status**
- 5 Operator loading/unloading backlog tasks**

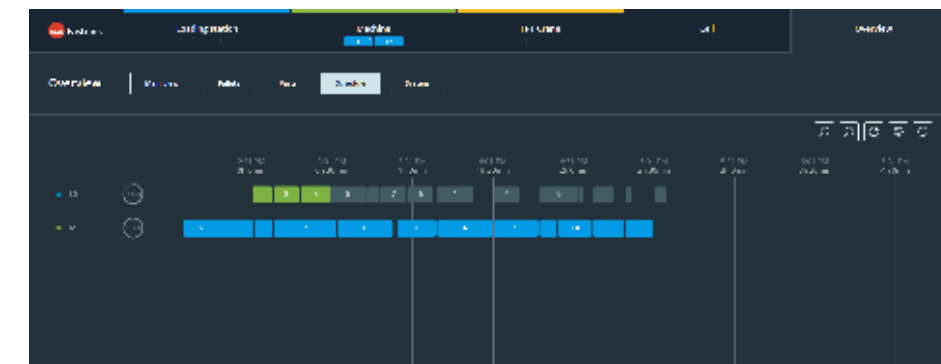

MMS can schedule production automatically based on production orders or FIFO.

WHEN	TOOL	REQUIRED	MISSING LIFE
2:38 PM	6001 Shoulder milling tool CoroMill 390	1 pcs	00:00:55
2:38 PM	6044 Ball nose cutter for roughing CoroMill@ 216	16 pcs	05:40:05
2:38 PM	6056 Deep and narrow grooving CoroMill QD	3 pcs	02:10:10
4:41 PM	3006	3 pcs	03:07:16

MMS Advanced package enables tool planning and status views for the easier cutting tool maintenance.

Run and grow your operations...



...throughout the system lifecycle.

Stay aware & optimize your system

myFastems – Your Digital Service

BE INFORMED

- Real-time information and notifications, accessible anywhere and anytime
- First-aid tips and recovery instructions available for proactive problem-solving

ENHANCED SERVICE MANAGEMENT

- Easy access to service history and reports
- Guided spare part inquiries with photos
- Recommendations on replacing spare part key components

WE ARE ONE CLICK AWAY

- Increase system' run time with direct access to our 24/7 assistance
- Get support more efficiently with error-coded support requests

EXTENDED PERSPECTIVE

- Follow service KPIs (utilization, automation index, MTBF, MTTR) for improvement opportunities based on measured data)
- Utilize the full potential of your system with optional monthly reports for comprehensive system insights.

Unleash the full potential of your manufacturing

Lifecycle Services

EVERYDAY RELIABILITY

Benefit from Genuine Fastems Spare Parts

- Expert spare part support and engineering over the lifecycle
- Ensure the fitting spare parts for your system
- 12-month warranty
- Flexible delivery globally
- Express shipment option

Contact Your Local Service Team

- Quick troubleshooting and system recovery
- Local service engineers speaking your language

GROW TOGETHER

Modify and Extend Your Systems

- Enhance your system via software update and new modules
- Extend with additional hardware

Build Your Skills & Competence

- Comprehensive training for operators and maintenance personnel
- Process optimization support by our experts

ALWAYS AVAILABLE

Ensure Your Optimal Operations - Also in The Long Run

- Preventive maintenance: scheduled on-site visits from Fastems experts
- 8760 support: professional 24/7 technical remote support
- Security, compliance, and productivity updates to your control systems.
- Tailored software development
- Care management services



Rethink your CNC manufacturing.

- ▶ **Production is a team play.** We help you to integrate your data systems, machines and people to work as ONE. By doing so you reduce costs, increase revenue, improve lead times and ensure consistent quality while minimizing waste, WIP and delays.

Fastems supplies intelligent CNC automation, software and services for high mix CNC manufacturing. We are an open integrator with a library of ready-made machine interfaces for over 90 different machine tool brands.

KEY NUMBERS:

- 40+ years of automation experience
- 5,000+ installations in Europe, North America, and Asia
- extendable & long-life systems
- 24/7 customer support

Read more at
www.fastems.com/fpt

